

Precision driven **sound innovation**

Clear minds thrive
in a quite environment.



Various models for Office

At Sonichive, our range of silence booths and pods caters to various workplace needs. The Solo Silence Booth offers a private, sound-insulated space for confidential calls. The Duo Silence Booth is perfect for critical discussions or quiet chats with colleagues. The Quartet Silence Booth supports both quick team huddles and extended discussions, enhancing productivity and collaboration. The Hexa Silence Booth is designed for spontaneous discussions and team meetings, fostering teamwork and innovation.





Unmatched Durability in Silence Pods

Made with high-grade materials like reinforced steel and impact-resistant panels. Their resilient construction ensures long-lasting performance.



Key features that a smart pod possesses



Sound Insulation
Tempered Glass



Damping Feet



Centrifugal Fan



Preferred Furniture



Sound Insulation



Lighting



Fastening Assemble



Motion Sensor

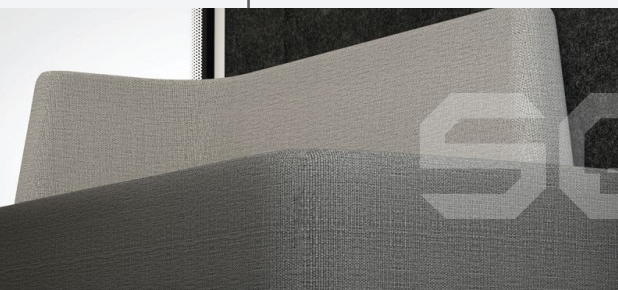

Solo Silence Booth

sonichive

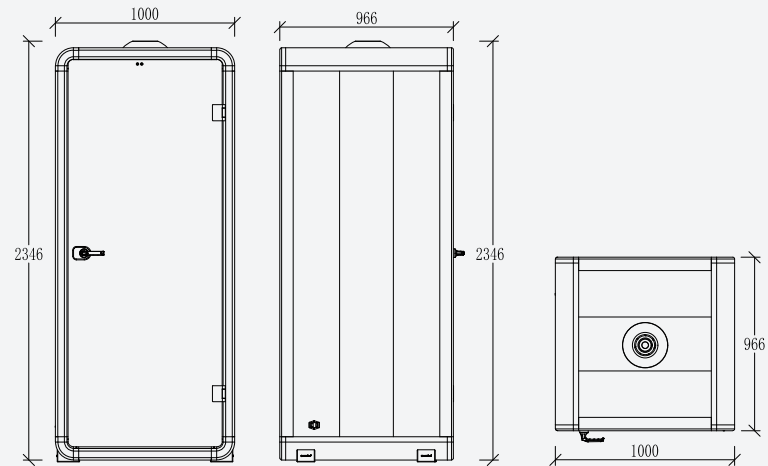

Product model	: Solo Silence Booth
Booth facilities	: <ul style="list-style-type: none"> ▶ 100-240V/50-60Hz power supply. ▶ 4000K/421LM natural lighting system. ▶ Centrifugal fan. ▶ Motion sensor and switch control for light and fan. ▶ Emergency safety hammer.
Furniture options	: ST-01 desk*1 SY-01 chair*1
Carpet colour	: Dark grey
Dimensions	
Package size	: W2270*D550*H1080mm
External size	: W1000*D936 H2346mm
Internal size	: W840*D900*H2140mm
Gross weight	: 279kg
Net weight	: 235kg

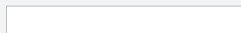

S115



S235



S169



S201



S211

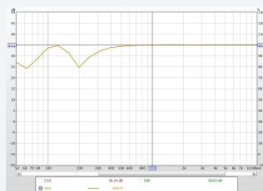

Speech intelligibility

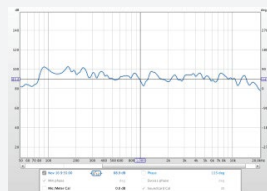

Frequency response

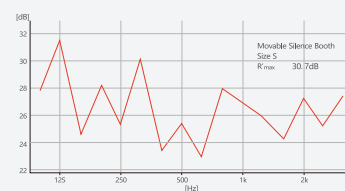

Sound insulation test

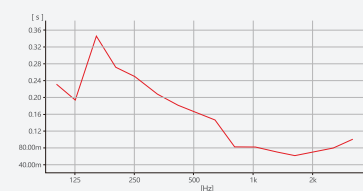

Reverberation time test

Size S RT
 Cursor values
 R: 18dB
 T20: 0.1s

Solo Silence Booth

sonichive

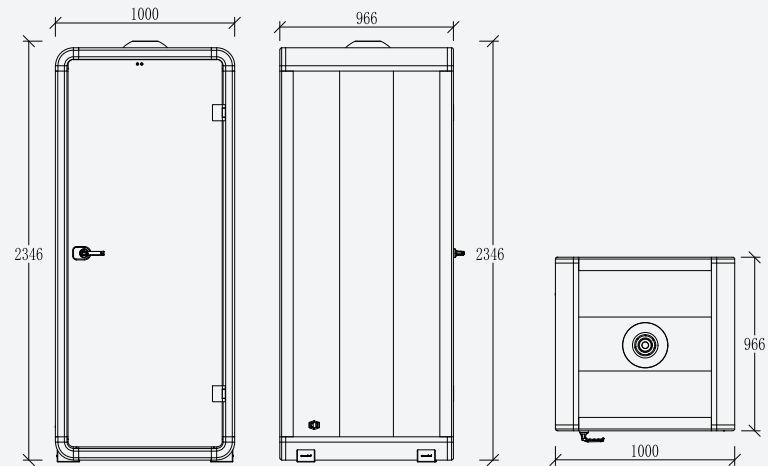

Product model	: Solo Silence Booth
Booth facilities	: <ul style="list-style-type: none"> ▶ 100-240V/50-60Hz power supply. ▶ 4000K/421LM natural lighting system. ▶ Centrifugal fan. ▶ Motion sensor and switch control for light and fan. ▶ Emergency safety hammer.
Furniture options	: ST-02 desk*1 SY-01 chair*1
Carpet colour	: Dark grey
Dimensions	
Package size	: W2270*D550*H1080mm
External size	: W1000*D936*H2346mm
Internal size	: W840*D900*H2140mm
Gross weight	: 279kg
Net weight	: 235kg

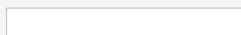

S115



S235



S169



S201



S211

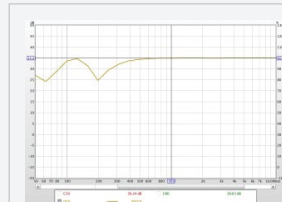

Speech intelligibility

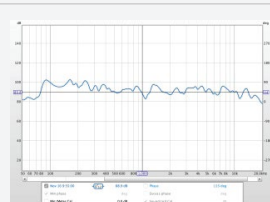

Frequency response

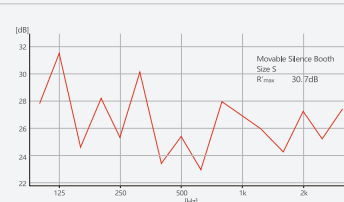

Sound insulation test

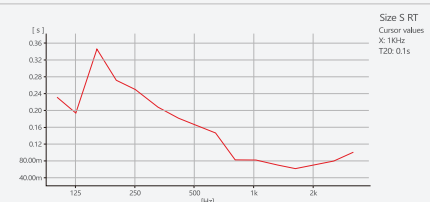

Reverberation time test

Duo Silence Booth

sonichive

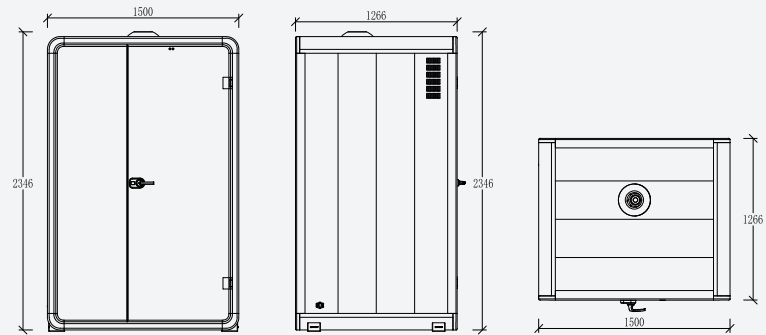

Product model	: Duo Silence Booth
Booth facilities	: <ul style="list-style-type: none"> ▶ 100-240V/50-60Hz power supply. ▶ 4000K/879LM natural lighting system. ▶ Centrifugal fan. ▶ Motion sensor and switch control for light and fan. ▶ Emergency safety hammer.
Furniture options	: ST-03 desk 1 SY-01 chair*2
Carpet colour	: Dark grey
Dimensions	
Package size	: W2270*D910*H1080mm
External size	: W1500*D1236*H2346mm
Internal size	: W1340*D1200*H2140mm
Gross weight	: 450kg
Net weight	: 390kg

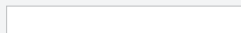

S115



S235



S169

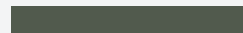

S201



S211

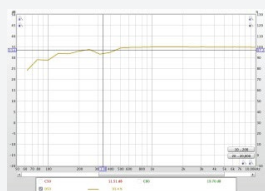

Speech intelligibility



Frequency response

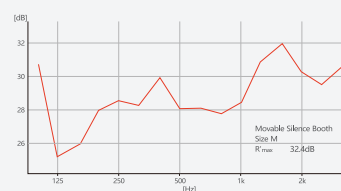

Sound insulation test

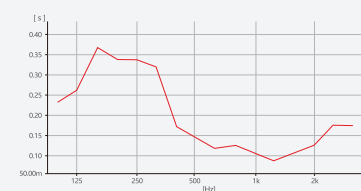

Reverberation time test

Size M RT
 Cursor values
 250Hz
 T20: 0.1s

Duo Silence Booth

sonichive

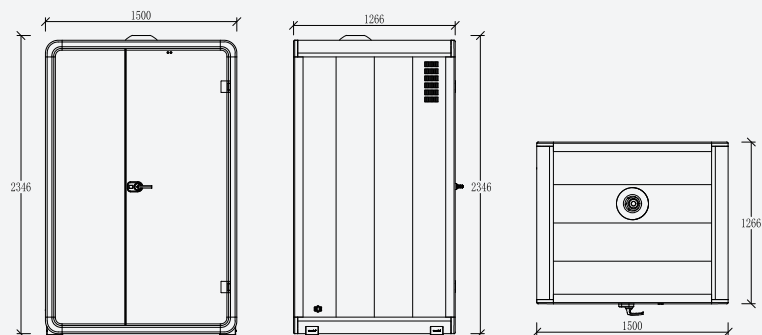

Product model	: Duo Silence Booth
Booth facilities	: <ul style="list-style-type: none"> ▶ 100-240V/50-60Hz power supply. ▶ 4000K/879LM natural lighting system. ▶ Centrifugal fan. ▶ Motion sensor and switch control for light and fan. ▶ Emergency safety hammer.
Furniture options	: ST-04 desk*1 SY-02 chair*1
Carpet colour	: Dark grey
Dimensions	
Package size	: W2270*D910*H1080mm
External size	: W1500*D1236*H2346mm
Internal size	: W1340*D1200*H2140mm
Gross Weight	: 450kg
Net weight	: 390kg

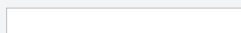

S115



S235



S169



S201



S211

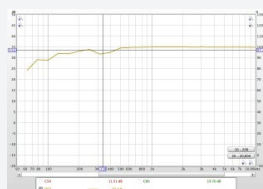

Speech intelligibility

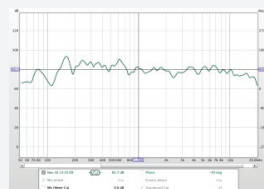

Frequency response

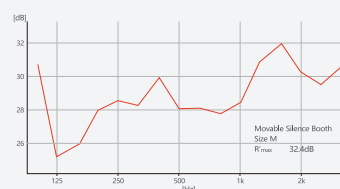

Sound insulation test

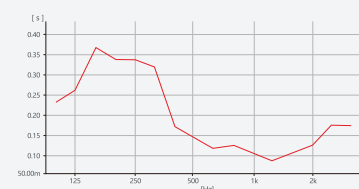

Reverberation time test

Size M RT
Cursor values
x: 164Hz
T20: 0.1s

Duo Silence Booth

sonichive

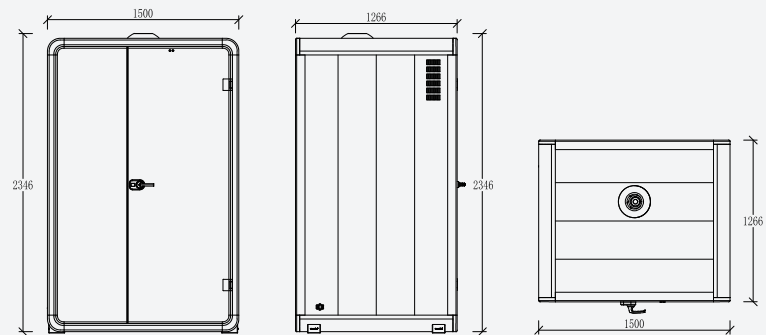

Product model	: Duo Silence Booth
Booth facilities	: <ul style="list-style-type: none"> ▶ 100-240V/50-60Hz power supply. ▶ 4000K/879LM natural lighting system. ▶ Centrifugal fan. ▶ Motion sensor and switch control for light and fan. ▶ Emergency safety hammer.
Furniture options	: ST-09 desk 1 SY-09(L/R) chair * 2
Carpet colour	: Dark grey
Dimensions	
Package size	: W2270*D910*H1080mm
External size	: W1500*D1236*H2346mm
Internal size	: W1340*D1200*H2140mm
Gross weight	: 450kg
Net weight	: 390kg

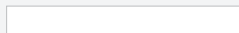

S115



S235



S169



S201



S211

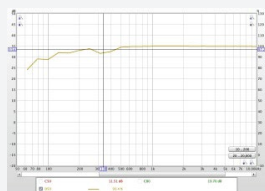

Speech intelligibility

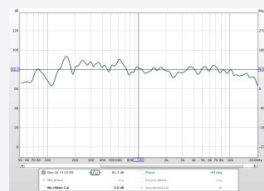

Frequency response

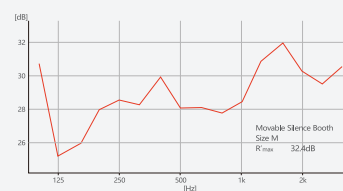

Sound insulation test

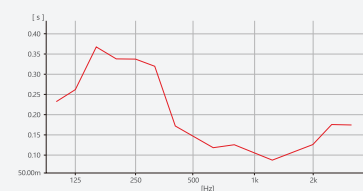

Reverberation time test

Size M RT
 Cursor values
 T1: 154s
 T20: 0.1s

Quartet silence Booth

sonichive

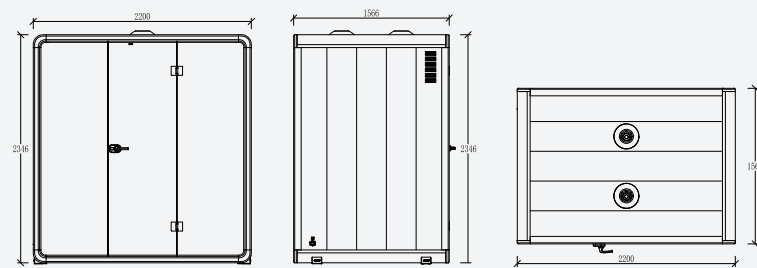

Product model	: Quartet silence booth
Booth facilities	: <ul style="list-style-type: none"> ▶ 100-240V/50-60Hz power supply. ▶ 4000K/879LM central lighting. ▶ 4000K natural background lighting on both side. ▶ Double centrifugal fan. ▶ Motion sensor and switch control for light and fan. ▶ Network port. ▶ Emergency safety hammer.
Furniture options	: ST-05 desk 1 SY-05(L/R) sofa 2 SJ-01 TV bracket (Optional)
Carpet colour	: Dark grey
Dimensions	
External size	: W2200*D1536*H2346mm
Package size	: W2270*D1060*H1080mm
Internal size	: W2040*D1500*H2140mm
Gross weight	: 648kg
Net weight	: 596kg

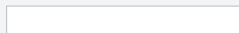

S115



S235



S169

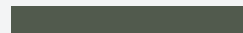

S201



S211

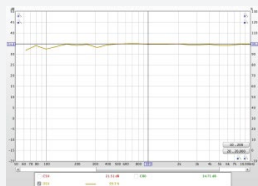

Speech intelligibility

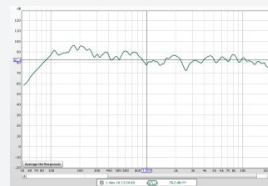

Frequency response

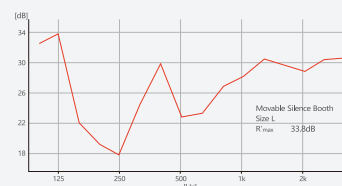

Sound insulation test

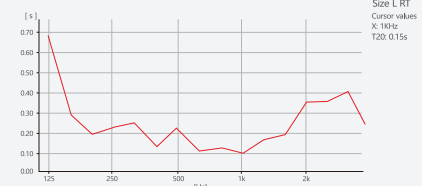

Reverberation time test

Hexa Silence Booth

sonichive

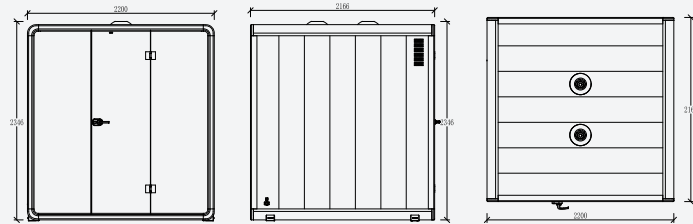

Product model	:	Hexa Silence Booth
Booth facilities	:	<ul style="list-style-type: none"> ▶ 100-240V/50-60Hz power supply. ▶ 4000K/1500LM central lighting. ▶ 4000K natural background lighting on both side. ▶ Double centrifugal fan. ▶ Motion sensor and switch control for light and fan. ▶ Network port. ▶ Emergency safety hammer.
Furniture options	:	ST-06 desk 1 SY-06(L/R) sofa 2 SJ-01 TV bracket (Optional)
Carpet colour	:	Dark grey
Dimensions	:	
Package size	:	W2270*D1190*H1080mm
External size	:	W2200*D2136*H2346mm
Internal size	:	W2040 D2100*H2140mm
Gross weight	:	790kg
Net weight	:	721kg

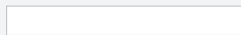

S115



S235



S169

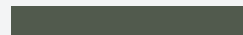

S201



S211

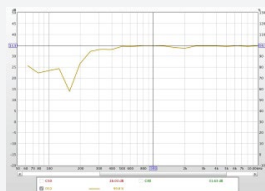

Speech intelligibility

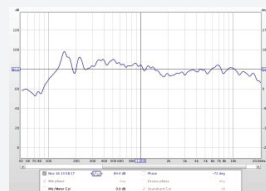

Frequency response

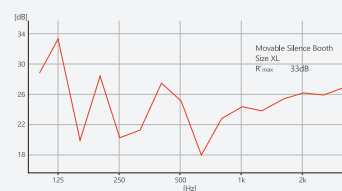

Sound insulation test

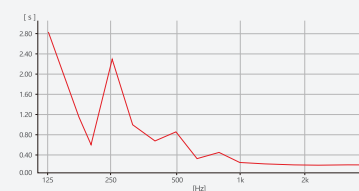

Reverberation time test

Size XL RT
Cursor values
K: 0.14s
T20: 0.15s

Octa Silence Booth

sonichive

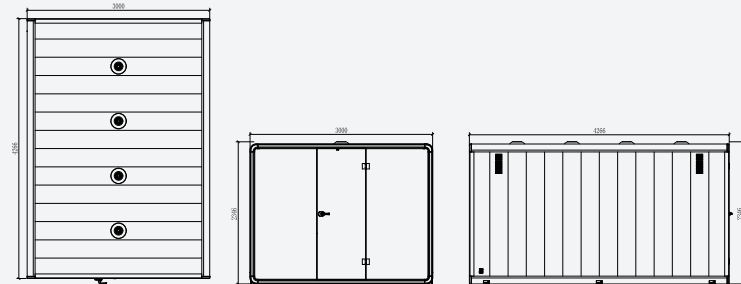

Product model	: Octa Silence booth
Booth facilities	: <ul style="list-style-type: none"> ▶ 100-240V/50-60Hz power supply. ▶ 4000K/2000LM central lighting. ▶ 4000K natural background lighting on both side. ▶ Four centrifugal fans. ▶ Motion sensor and switch control for light and fan. ▶ Network port. ▶ Emergency safety hammer.
Furniture options	: ST-10 desk 1 SY-03 chair*8 SJ-01 TV bracket (Optional)
Carpet colour	: Dark grey
Dimensions	
Package size	: W2910*D1000*H1120mm
External size	: W3000*D4236*H2346mm
	: W2260* D1110* H1250mm
Internal size	: W2840*D4200*H2140mm
Wooden frame	: W4300*D520*H335mm
Gross weight	: 1580kg
Net weight	: 1442kg

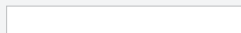

S115



S235



S169



S201



S211

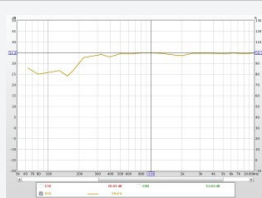

Speech intelligibility



Frequency response

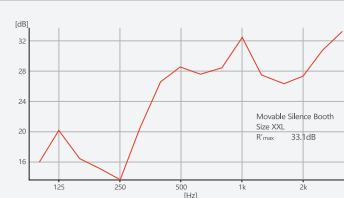

Sound insulation test

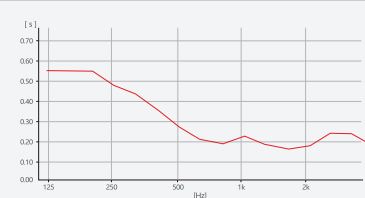

Reverberation time test

A silent sanctuary, with in your walls

The home pod optimizes sound quality for remote work, casual conversations, or focused studying. It blocks external noise and minimizes echoes, ensuring you can concentrate without distractions. Ideal for virtual meetings, chats, or study sessions, the home pod offers a quiet, controlled space, enhancing productivity and enjoyment in activities requiring clear, uninterrupted audio.

sonichive





sonichive

Feature to Refine Your Home's Silence



Ceiling ambient light



Fresh air circulation



Wood handle



Adjustable lamp



Writing desk



Power panel



Arm-curved sofa



Mobile casters

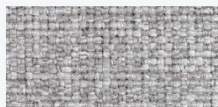

Mint
SF-1128

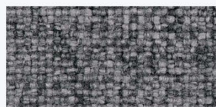

Southsea
SUNDAY-045



Cloud
SF-1103



Hazel
SF-1101



Storm
SF-1105



Taffy
SF-1108

Product parameters

HOME POD	
Product name	House No.1
Exterior size	1100* 900* 2100mm
Interior size	1000* 800* 1960mm
Package size	2210*630*1280mm
Booth net weight	198KG
Booth material	Carbon plastic sound insulation board. PET acoustic board, polyester fiber acoustic cloth, aluminum profiles 304 stainless steel. ABS engineering plastic
Furniture material	Birch multilayer board, polyurethane sponge, polyester sofa fabric
Power input	100-240V/50-60Hz
power output	220V 5A, 5V 2.1A
Maximum power	1kw
Ambient Light	3.5W, 170LM, 4000k
Reading light	5W, 160LM, 3000K-6500K
Fan rotation speed	600-1500rpm
Air ventilation efficiency	> 30m ³ /h
Sound insulation volume	25db(3dB)
Language intelligibility	> 0.76 STI A+ studio level
Formaldehyde	0.05 EO level
Benzene	ND EO level
TVOC	0.29
Function configuration	Adjustable fresh air system, adjustable writing desk. Ergonomic sofa, reading eye protection light. overhead ambient light. ush2.0 integrated power supply. 220v five-hole AC power supply. hidden removable casters



Enhance your home environment with a premium silence pod.



sonichive

sonichive

Premium Color Customization for Home Pods.

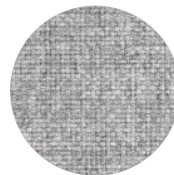
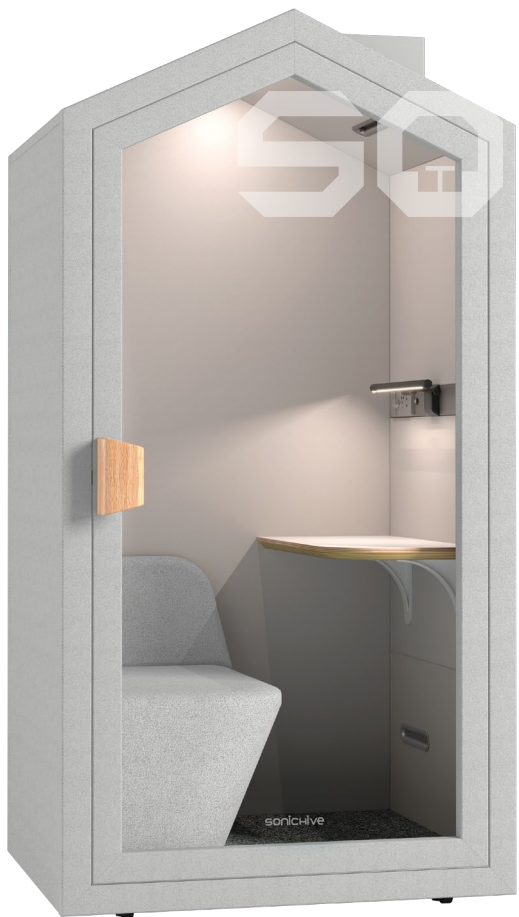

SF-1128

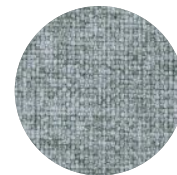

SF-1105

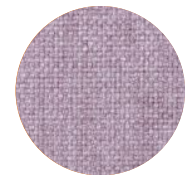

SF-1103

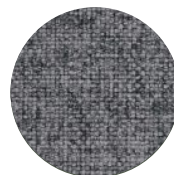

SUNDAY-045

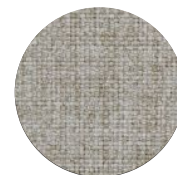

SF-1108

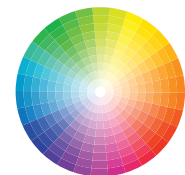

Custom Colour

Premium Colour Customization for Solo Silence Booth.

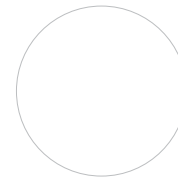

S115

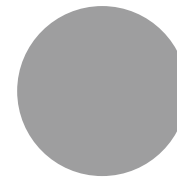

S235

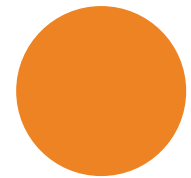

S169

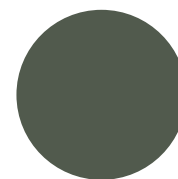

S201

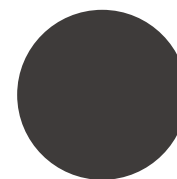

S211

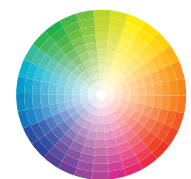

Custom Colour

Premium Colour Customization for Duo Silence Booth.

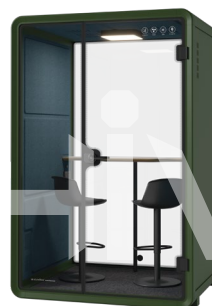

S115

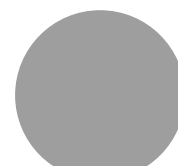

S235



S169



S201

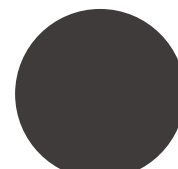

S211

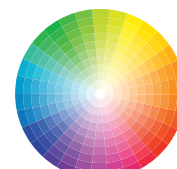

Custom Colour

Premium Colour Customization for Quartet silence booth

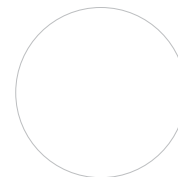

S115

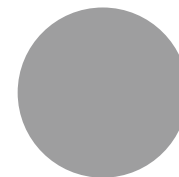

S235

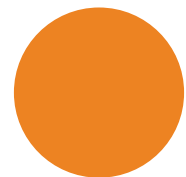

S169

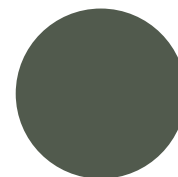

S201

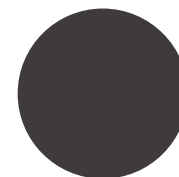

S211

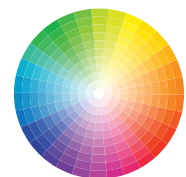

Custom Colour

Premium Colour Customization for Hexa Silence Booth.

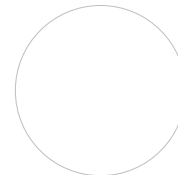

S115

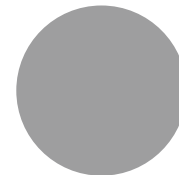

S235

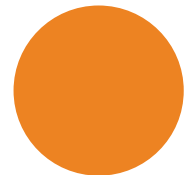

S169

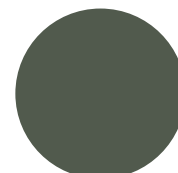

S201

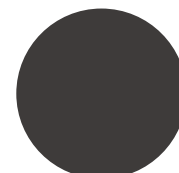

S211



Custom Colour

sonichive

Sonic Hive Furniture Trading,
Ground Floor, Al Wasl Building, Next to Dubai Mall/
Burj Khalifa Metro Station, Exit 2, Sheikh Zayed Road, Dubai, United Arab Emirates.
Ph: +971 58 555 00 99 | Email: info@thesonichive.com | www.thesonichive.com

