

PRODUCT DATA SHEET

Dual Benching Height Adjustable Desk

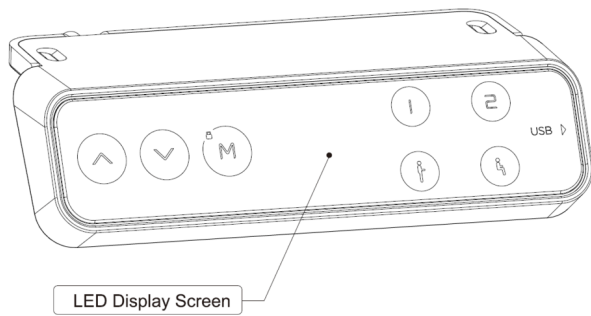

HS13B-1
4 programmable positions.
Up/down switch.
Safety screen lock.
USB charging.

▪ Dual Benching ▪ Functional

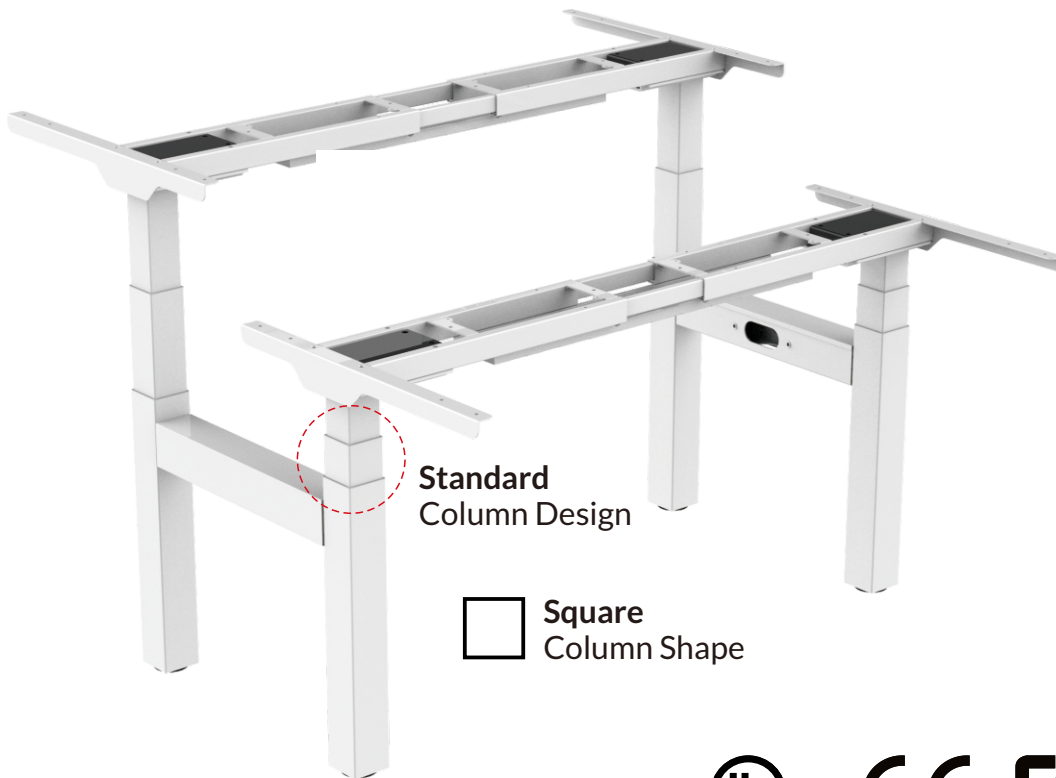

represent models
featured
“Ease of Maintenance”



SPECIFICATIONS

Max. Load Capacity:

275 lbs/125 kg

Speed:

38mm/s

Power Type:

100V-240V

Decibel:

<50dB

Stroke:

25.6"/650mm

Height Range:

22.8"-48.4"/580-1230mm

Recommended Tabletop Dimensions:

47.2"-78.7"/1200-2000mm(Width)

23.6" | 31.5" / 600 | 800mm(Depth)

Frame Color: ■ ■ ■ □

FEATURES:

- Dual benching unit enables two individual workspace.
- Three programmable memory presets and sit/stand reminder system(Optional).
- Enhanced anti-collision feature(Optional).
- Impeccable protection software, including automatic failure detection.
- Constant speed even overloaded, accurate height adjusted within 2mm error.
- Reliable control system, 100% aging test qualified for the control box.
- Designed and tested to applicable US Energy Star & EU ERP standards.

Product 2D Drawings

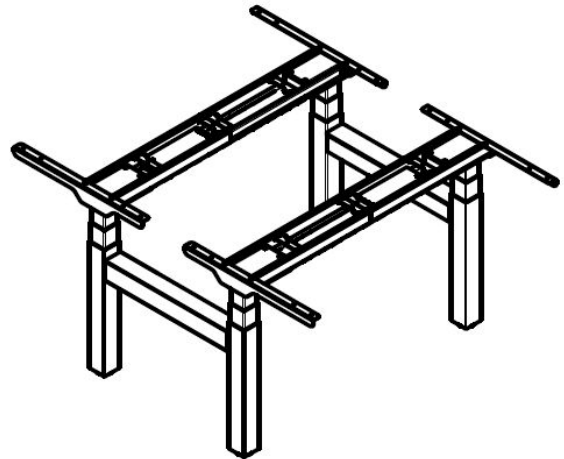
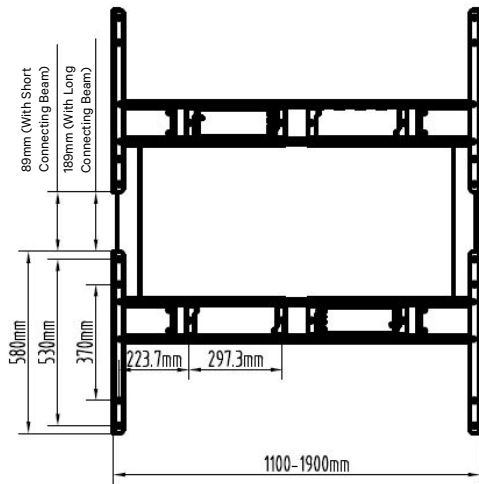
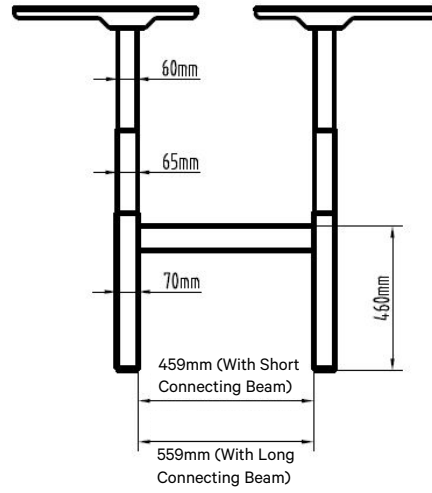
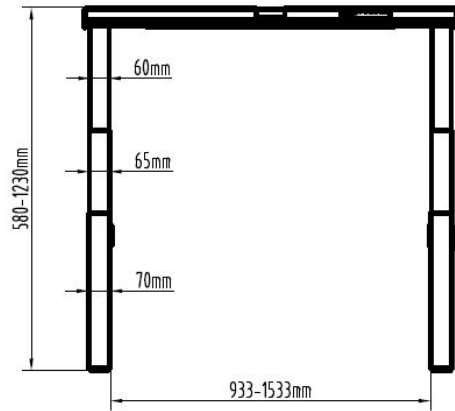

PRODUCT DATA SHEET

Dual Benching Height Adjustable Desk

Specifications

- Height Range: 22.8"-48.4"/580-1230 mm
- Width Range: 43.3"-74.8"/1100-1900 mm
- Recommended Tabletop Dimension:
47.2"-78.7"/1200-2000mm (Length)
23.6"-31.5"/600-800mm (Width)
(There are long and short connecting beam)
- Recommended Privacy Penal Dimension: 0.03"-0.99"/1-25mm
- Load Capacity: 275lbs/125kg
- Speed: 38mm/s
- Noise Level: <50 dB
- Low Standby Power: <0.5W
- Colors: White, Black, Gray
- Holeless Design Column
- Anti-Collision Function
- Optional control panel.
- Optional privacy panel adapters & cable management components.

ET223H (IB) additional features

- Built-in sensor for anti-pinch hand function, tabletop anti-collision function
(adjust functions according to gear)
- Dual DC33V output (optional USB charging, wireless charging function, etc.).
- Double RJ45 interfaces (optional mobile phone remote via Bluetooth Dongle).

Certification

- ET223H Certifications: CB, CE-EMC, CE-LVD, CE-ErP, RoHS, FCC, UL, CUL, RCM, KC
- ET223H(IB) Certifications: CB, CE-EMC, CE-LVD, ROHS, FCC, UL, CUL, RCM.